

ABB MEASUREMENT & ANALYTICS | APPLICATION DESCRIPTION

Introduction to landfill applications

Analytical applications



Introduction

Landfills (Garbage Dumps) have recently become a very important source of energy and revenue for municipalities and private landfill owners. They are discovering that by capturing the natural hydrocarbon off gassing that occurs when refuse degrades, that they can improve the environment while making some revenue by selling the energy that is generated. This application sheet will explain some of the issues involved. Because Natural Gas itself has become more expensive, the feasibility of using the low quality gas produced in a landfill has come in to its own. The higher revenue potential allows more processing to be economical. Also, the new turbine technology to burn this low Btu fuel to generate electricity has been perfected.

It is environmentally unfriendly to allow these naturally occurring green house gases to diffuse into the atmosphere. The gases of environmental interest are Methane and CO₂, Carbon Dioxide. There are regulations that require municipalities or private firms to mitigate these gases before they reach the environment. So trapping and using the gases rather than letting them go into the air is of great importance.

There are two main ways to use this gas once it is trapped. One is to process or clean it sufficiently to sell as pipe line quality Natural Gas. This generally requires a source of richer gas to blend with it, as the Btu of the landfill gas is usually around 600 to 800 Btu/scf. But this can in some instances be done. The other method is to burn the gas at the site in a co-generation plant and then sell the electricity back to “the Grid”. This is very popular, especially in areas where brown out is likely in high use times.

Passive vs. Active collection

Landfills typically employ one of two methods to control the migration of landfill gases; passive and active systems. Passive systems rely on natural and man-made migration paths to control gas migration. Impermeable liners (e. g., clay and/or geosynthetic membranes) can be used on the top, bottom and sides of landfills to create artificial migration paths and prevent the escape of dangerous gases. These barriers can also limit gases venting to the atmosphere and cause those gases to migrate toward collection wells (whether passive or active).

Collection wells (whether active or passive) are strategically placed throughout the landfill site. How many collection sites and their placement depends upon the type of material in the landfill, the well depth, soil compaction, water content and migration paths. Passive collection systems can be flared or use chemical reactions to eliminate any components that might pose a public nuisance or danger.

Active collection systems may be employed when it has been determined that the economic benefits might outweigh the system costs. Active systems use the gas produced by the landfill to heat or power nearby facilities. Some systems produce enough energy that it is worthwhile to consider generating electricity and selling it back to the local power grid. Active systems may employ blowers, vacuums, compressors, generators and other specialized equipment to collect and use the landfill gases.

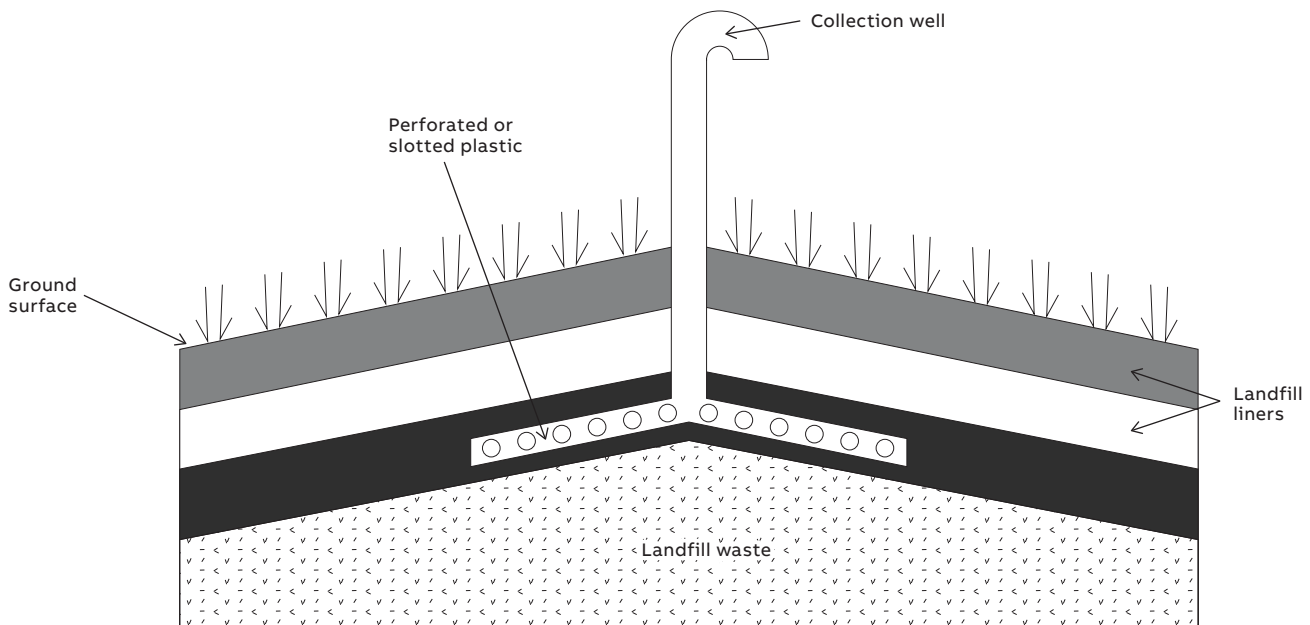

Fig. 1 Passive collection vent (illustration courtesy of ATSDR)

Life cycle and feasibility of active collection

A landfill operation has a fairly well defined life cycle. The life cycle has four phases (Figure 2):

Phase I

Phase I, is aerobic (oxygen is present). The output of the landfill is primarily nitrogen with some CO2 and hydrogen.

Phase II

Phase II (and subsequent) phases are anaerobic (no oxygen present). Phase II produces mostly CO2 with lesser degrees of nitrogen and hydrogen.

Phase III

Phase III you will see the CO2 starting to level off at around 50%, while the methane is increasing rapidly to about 50%. Nitrogen and hydrogen are down around 5%.

Phase IV

Phase IV, nitrogen has leveled off to about 2-5% and CO2 and methane are fairly constant at about 50% each.

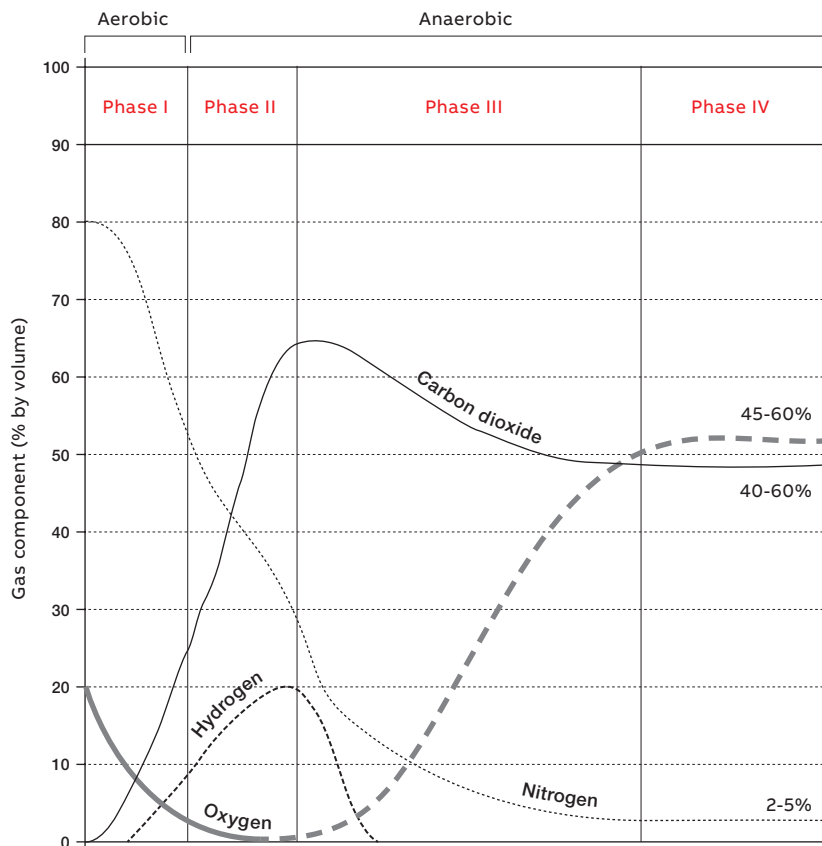

Note: Phase duration time varies with landfill conditions

Source: EPA 1997

Fig. 2 Landfill phases of operation (Graph courtesy of EPA)

A number of factors can be useful in determining the feasibility of using landfill gases for power generation and on-line gas analysis.

Methane	54%
Carbon Dioxide	42%
Nitrogen	3.1%
Oxygen	0.8%
Carbon Monoxide	Indicates under ground combustion
Hydrogen Sulfide	Typically less than 1%

- Does the landfill hold more the 1 million tons of waste?
- What is the waste material?
 - Biodegradable waste
 - Sewage treatment sludge (raw and/or secondary)
 - Slaughterhouse waste
 - Food waste
 - Organic component of mixed municipal waste
 - Biomass (like maize)
- Does the landfill cover more than 40 acres?
- Is the waste at least 35 feet deep?
- Warm, moist climates are better suited than cool, dry climates.

- Is the energy user nearby?
- Industrial guidelines suggest that gas recovery is feasible if the landfill produces 1 million cubic feet of gas per day.
- Average landfill gases typically run about 500BTU/cubic foot. They may require blending before being sold to a local natural gas pipeline. Typical component break down for Landfill Applications:
- Is this an abandoned landfill or is it still in use? Landfills tend to be most productive in their first 20 years of service although some continue to produce for 50 years or more.
- Where is your landfill with regard to its life cycle?

The amount of energy that any specific landfill can produce will be dictated by many factors (size, age, materials in the landfill, climate, soil conditions, etc.), but typical installations tend to range between 3 and 8 megawatts. A 6 megawatt plant would produce about 47 million kilowatt-hours per year, enough to supply about 3,200 homes. Due to the cost of maintenance on this size of electric generation equipment, an on-line GC is usually easily justified.

Landfill application specifications

Configuration files for landfill

Totalflow has created configuration files to support Landfill applications. However, configuration files alone will NOT necessarily turn your NGC into a Landfill application. The Landfill application requires special columns specifically designed for the Landfill application. There are also some setup parameters that are not addressed through the configuration files. The Landfill application also requires the Landfill Sample System to provide adequate filtering and proper inlet pressures.

The Landfill Configuration file makes the following assumptions:

- Landfill application (landfill columns)
- 3 sample streams
- 1 calibration stream
- NGC Interface on Com2

Landfill Configuration file part number – 2103066-XXX

Component	Readable ranges (mol%)	Minimum detectable levels MDL (mol%)	Relative standard deviation (% RSD)
Propane+	0-20	0.005	1.0
Methane	0-100	0.005	0.5
Ethane	0-100	0.005	1.0
Carbon Monoxide	0-10	0.005	1.0
Carbon Dioxide	0-50	0.005	0.5
Nitrogen	0-100	0.005	1.0
Oxygen	0-20	0.005	1.0
Hydrogen Sulfide	0-1	0.005	1.0
Hydrogen	0-100	0.5	1.0

Landfill application parameters calibration blend

Component	Standard concentration (mole%)
Propane+	0.08
Methane	48.505
Ethane	0.13
Carbon Monoxide	0.25
Carbon Dioxide	45.0
Nitrogen	0.50
Oxygen	0.50
Hydrogen Sulfide	0.035
Hydrogen	5.00

Recommended calibration blend for landfill applications

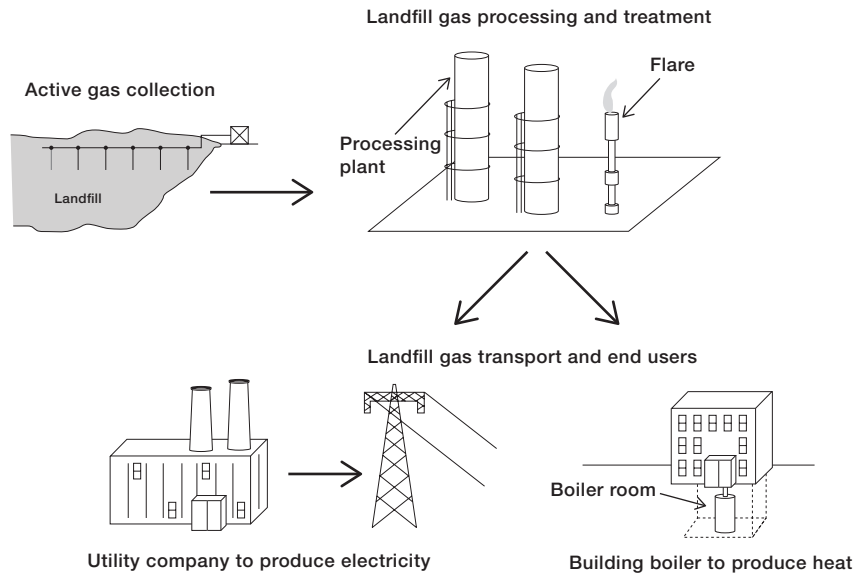

Fig. 3 Active collection system (Illustration courtesy of ATSDR, an agency of the CDC)

Application parameters

Table 1 reflects the parameters that the Landfill Application is designed operate within.

Calibration blend

To properly calibrate the NGC for Landfill Applications, a special calibration blend is required. This blend can be ordered from Totalflow or custom blended per our requirements by your vendor.

Custom calibration blends are acceptable, however, our recommended blend has the necessary components to support manual Peak Find. Custom blends that do not have the key components will not support factory settings for manual peak find without special procedures to identify the peaks for the missing components.

Recommended sampling system

Totalflow has put together a sample system that addresses the low pressures inherent in a landfill operation. Our NGC needs about 10-20psig (see specifications) at its sample stream inlet for proper operation. The landfill sample system uses a Di-Vac[®] pump to increase the pressure of the sample stream. A back pressure regulator allows the operator to adjust the inlet stream to an appropriate level (10-20psig). Most of the sample stream will be vented through the back pressure regulator. It can be vented to atmosphere or returned to the process stream. Being at a higher pressure it can easily be reintroduced to the process stream. The Metering Valve (needle valve) lets the operator adjust the sample flow rate.

The flow rate is monitored with a Rotameter flow device. Flow should be set to about 75% of full-scale (~475cc/minute) on the Rotameter. Normal operation of the NGC is responsible for about 50cc/minute. The majority of the 475cc/minute is to accommodate the speed loop and to provide good real-time analysis of the sample. Finally, before the process stream is introduced to the NGC, it passes through Totalflow's Filter System (2102494-001 or 2102024-002) to ensure that dry and uncontaminated gases are passed to the NGC.

There are two points in the drawing (Figure 4) that refer to “SAMPLE OUT” or “SAMPLE OUTPUT TO NGC INLET”. The “SAMPLE OUT” is basically sample gases that flow out of the back pressure regulator. These gases can be properly vented or, due to their being at a higher pressure, returned to the process stream. “SAMPLE OUTPUT TO NGC INLET” is the line that is tied into the NGC’s sample stream inlet for analysis.

For more information on the NGC Landfill Application, please contact your local ABB representative.

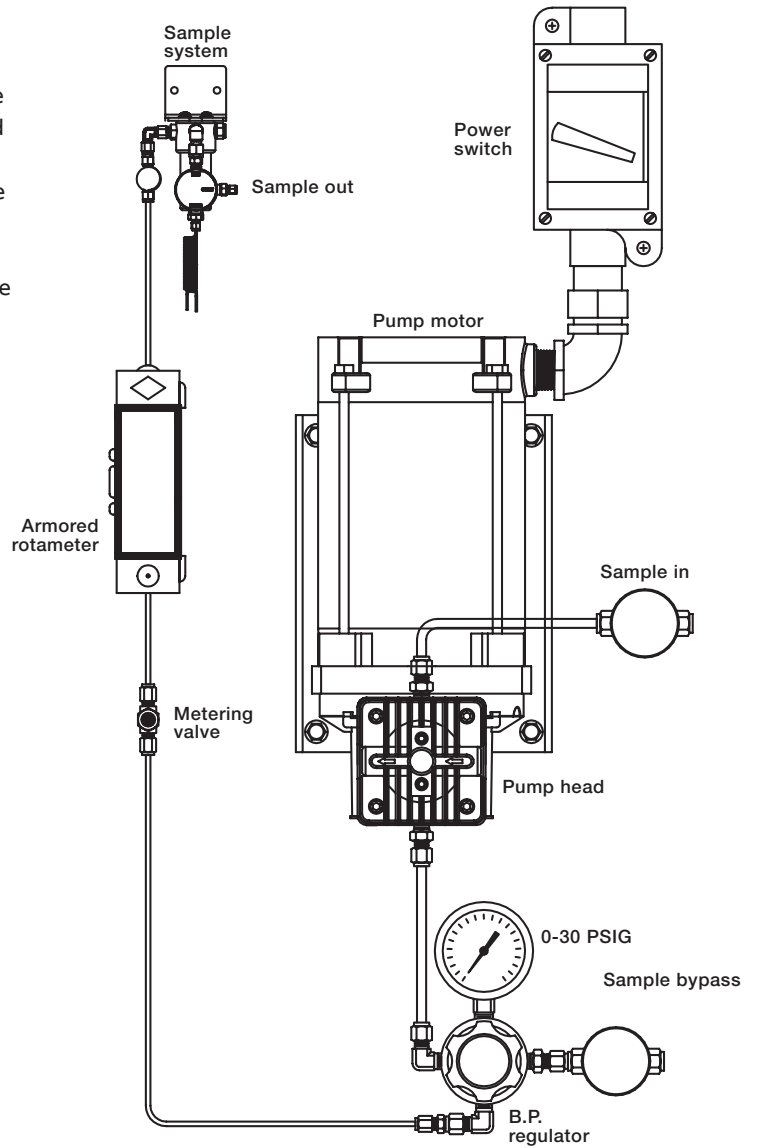

Fig. 4 Totalflow sampling system for landfill applications



—

ABB Inc.

Measurement & Analytics

Quotes: totalflow.inquiry@us.abb.com

Orders: totalflow.order@us.abb.com

Training: totalflow.training@us.abb.com

Support: totalflowsupport@us.abb.com
+1 800 442 3097 (opt. 2)

Main Office

7051 Industrial Boulevard

Bartlesville, OK 74006

Ph: +1 918 338 4888

www.abb.com/upstream

<https://new.abb.com/products/measurement-products>

<https://new.abb.com/contact-centers>

—

We reserve the right to make technical changes or modify the contents of this document without prior notice. With regard to purchase orders, the agreed particulars shall prevail. ABB does not accept any responsibility whatsoever for potential errors or possible lack of information in this document.

We reserve all rights in this document and in the subject matter and illustrations contained therein. Any reproduction, disclosure to third parties or utilization of its contents – in whole or in parts – is forbidden without prior written consent of ABB.

© Copyright 2020 ABB.
All rights reserved.