

SPECIFICATIONS

Mechanical

Mating Force: 90gf max. per Contact
Unmating Force: 10gf min. per Contact
Durability: 50 Cycles

Electrical

Current Rating: 0.5A DC
Contact Resistance: 50mΩ max. (for Mated height = 8mm)
 70mΩ max. (for Mated height > 8mm)
Dielectrical Withstanding Voltage: 200V
Insulation Resistance: 500MΩ min.(initial) , 100MΩ min.(after)

Physical

Housing: LCP, UL 94V-0 rated in Ivory White Color
Contact: Brass
Plating: 4~10u" min. Gold Plating on Contact Area
Metal Ear: Brass
Operating Temperature: -40 to +80

Board to Board Connector

QTS0 Series
0.60mm [.024"] Pitch
Vertical, Plug
for High Speed application

Mated with QTS1 Series

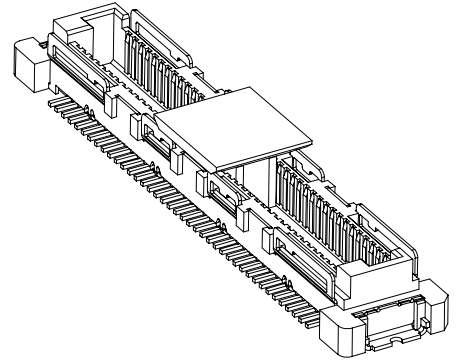

DRAWING

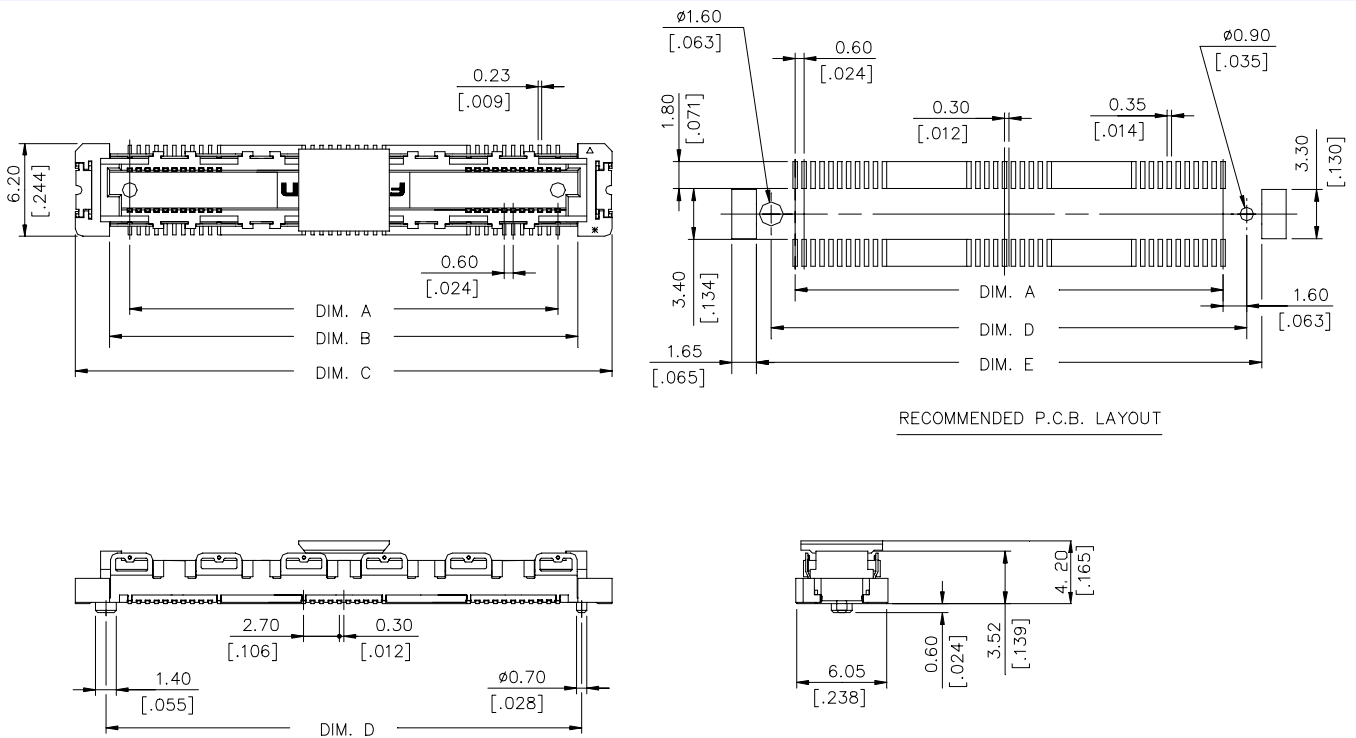

ORDERING INFORMATION

PRODUCT NO.: Q T S 0 * * * A - 1 1 2 1 - 9 F

Series Prefix _____
 S=0.6 [0.024] Pitch _____
 0=Plug _____
 No. of Pos. _____
 040=40 Pos.
 160=160 Pos.
 Contact Area Plating _____
 A=4~10u" Gold _____

F: Lead Free
 Package
 9=Tape&Reel(single) W/ Cap
 Metal Ear
 1=W/ ME
 Metal shield & Solder Type
 1=W/ S/P & SMT type
 Profile Height
 1=3.52 [0.139]

160	47.40 [1.866]	50.10 [1.972]	54.70 [2.154]	50.60 [1.992]	51.80 [2.039]
140	41.40 [1.630]	44.10 [1.736]	48.70 [1.917]	44.60 [1.756]	45.80 [1.803]
120	35.40 [1.394]	38.10 [1.500]	42.70 [1.681]	38.60 [1.520]	39.80 [1.567]
100	29.40 [1.157]	32.10 [1.264]	36.70 [1.445]	32.60 [1.283]	33.80 [1.331]
80	23.40 [.921]	26.10 [1.028]	30.70 [1.209]	26.60 [1.047]	27.80 [1.094]
60	17.40 [.685]	20.10 [.791]	24.70 [.972]	20.60 [.811]	21.80 [.858]
40	11.40 [.449]	14.10 [.555]	18.70 [.736]	14.60 [.575]	15.80 [.622]
POS.	DIM. A	DIM. B	DIM. C	DIM. D	DIM. E