

REV.	ECN. NO.	APPD.
A	BC-13-0055381	S. SZU
B	BC-13-0090212	Nick Lin
C	BC-14-0021203	Nick Lin

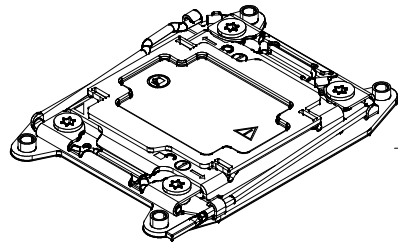

LGA2011-3 NARROW ILM  
P/N: PT44L12-4711

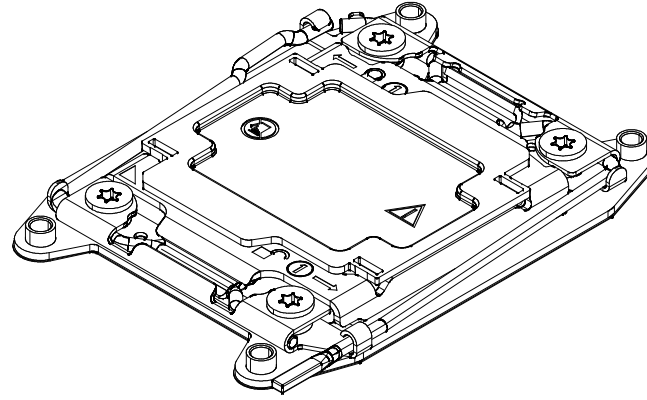

PLEASE REFER TO P. 2 & P. 3 FOR DETAILS

LGA2011 SOCKET  
P/N: PE201127-4355-01H

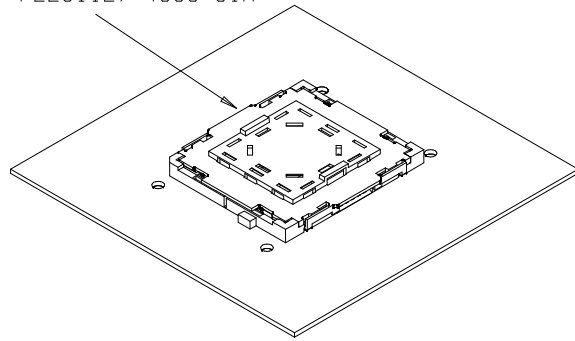

LGA2011 BACK PLATE  
P/N: PT44P41-4401

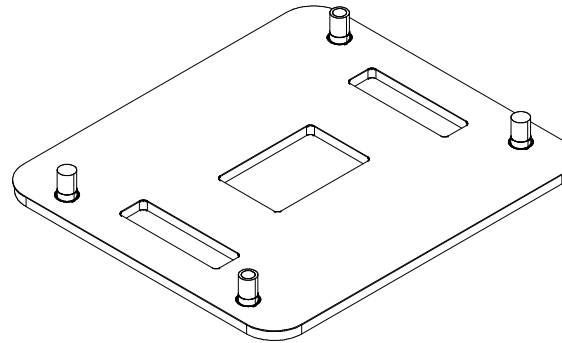

PLEASE REFER TO P. 4 FOR DETAILS

LGA2011-3 NARROW ILM + BP  
P/N: PT44A12-4711

NOTES:

1. AFTER LGA2011-3 SOCKET SURFACE-MOUNTED ON THE BOARD, TO ASSEMBLE THE ILM & THE BACK PLATE BY T20 6-LOBES SCREW DRIVER.
2. DO NOT REMOVE THE CAP ON THE SOCKET DURING ILM ASSEMBLY.
3. HARMFUL MATERIAL CONTROL PLEASE FOLLOW DOC. NO. "EPI12".
4. PLEASE CONTACT FOXCONN SALES REPRESENTATIVE TO VERIFY PRODUCT DETAIL & AVAILABILITY.
5. THE CONCENTRATIONS OF Br & Cl CAN SATISFY REQUIREMENTS OF HALOGEN-FREE IN DOC "EPI12".

X. ± 1.0	X. ° ± 1°	UNITS mm	NAME<INTENDED USE> LGA2011-3 NARROW ILM&BP	<b>FOXCONN®</b> FOXCONN INTERCONNECT TECHNOLOGY LIMITED.
.X ± 0.50	.X ° ±	MAT'L	PART NO.<INTENDED USE> PT44A12-4711	
.XX ± 0.30	.XX ° ±	FINISH	APPD: Nick Lin	CLASS: <input type="checkbox"/> CONFIDENTIAL <input type="checkbox"/> SECRET <input checked="" type="checkbox"/> GENERAL
.XXX ±	.XXX ° ±		Q' TY	CHKD: Dickie Huang Mac Peng
THESE DRAWINGS AND SPECIFICATIONS ARE THE PROPERTY OF FOXCONN INTERCONNECT TECHNOLOGY LIMITED, AND SHALL NOT BE REPRODUCED, COPIED OR USED IN ANY MANNER WITHOUT THE PRIOR WRITTEN CONSENT OF FOXCONN INTERCONNECT TECHNOLOGY LIMITED.			DR: Garnett Wu 4/27' 14	DWG NO. : 351-0000-1241
			SCALE 1:1 SHEET 1/4 REV. C	

IDEAS GENERATED DRAWING, DO NOT CHANGE BY HAND.

NOTES:

- ALL DIMENSIONS ARE IN MILLIMETERS.
- DIMENSIONING AND TOLERANCING PER ASME Y14.5M-1994.
- MATERIAL : LOAD PLATE/LEVERS/FRAME/CLEVIS STAINLESS STEEL;  
INSULATOR ON FRAME INSULATING MATERIAL (UL 94V-0);  
ILM NUT/COLLAR CARBON STEEL WITH Ni PLATING;  
HS NUT STAINLESS STEEL;  
DUST COVER THERMOPLASTIC (UL 94V-0);
- FOXCONN LOGO IS LOCATED APPROXIMATELY.
- ILM LOGO "2011-3 LM-N" IS LOCATED APPROXIMATELY.
- DATE CODE IS LOCATED APPROXIMATELY.
- PLEASE CONTACT INTEL FOR OFFICIAL KQZ RECOMMENDATION.
- HARMFUL MATERIAL CONTROL PLEASE FOLLOW DOC. N.O. "EP112".
- PLEASE CONTACT FOXCONN SALES REPRESENTATIVE TO VERIFY PRODUCT DETAILS & AVAILABILITY.
- P/N: PT44L12-4711

REV.	ECN. NO.	APPD.
------	----------	-------

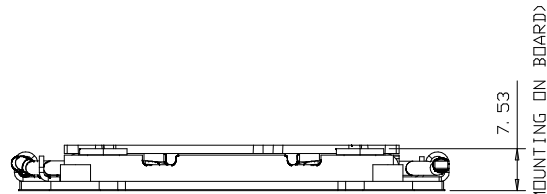
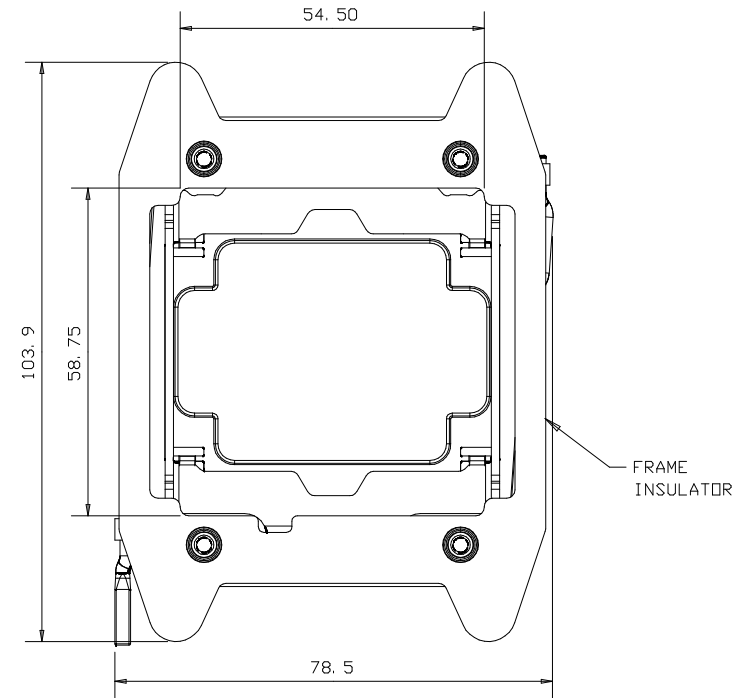
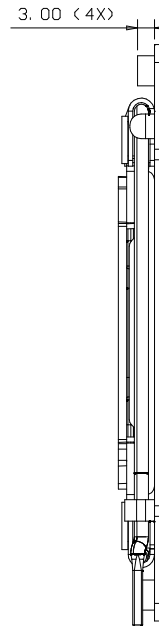
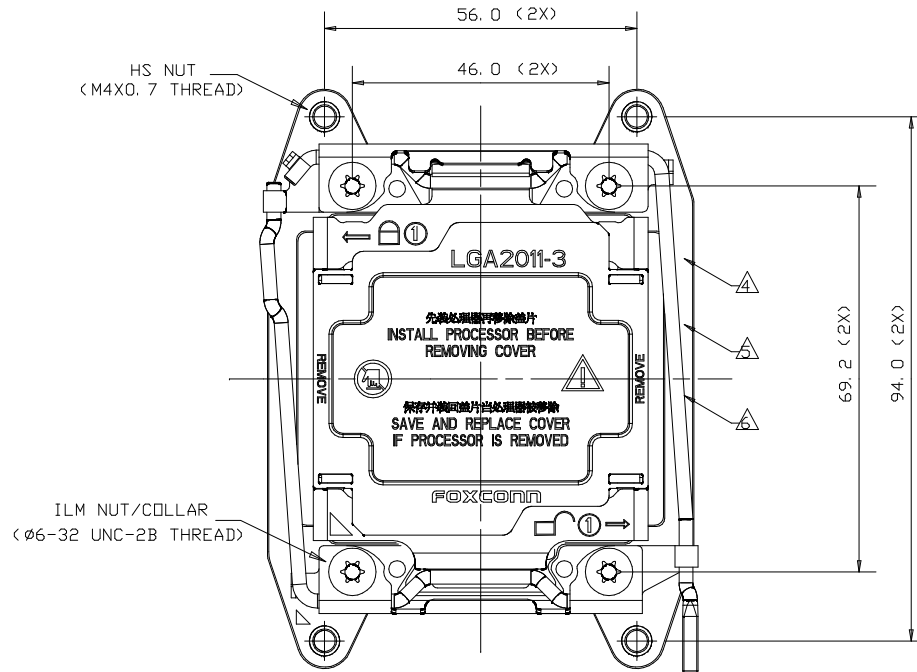
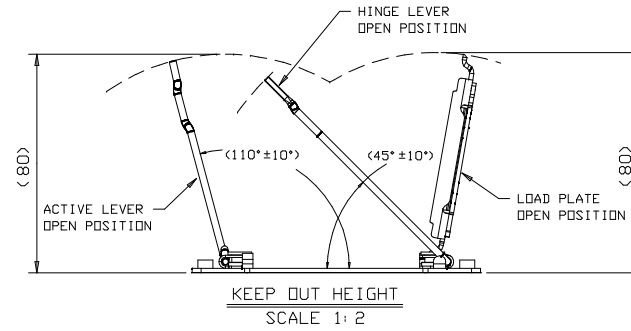

(AFTER MOUNTING ON BOARD)

X. ± 1.0	X. ° ± 1°	UNITS mm	NAME (INTENDED USE) LGA2011-3 NARROW ILM&BP	<b>FOXCONN®</b> FOXCONN INTERCONNECT TECHNOLOGY LIMITED. CLASS: <input type="checkbox"/> CONFIDENTIAL <input type="checkbox"/> SECRET <input checked="" type="checkbox"/> GENERAL TITLE: CUSTOMER DRAWING FOR LGA2011-3 NARROW ILM&BP DWG NO.: 351-0000-1241
. X ± 0.50	. X ° ±	MAT'L	PART NO. (INTENDED USE) PT44A12-4711	
. XX ± 0.30	. XX ° ±	FINISH	APPD: Nick Lin	SCALE SHEET REV. 1:1 2/4 C
. XXX ±	. XXX ° ±		Q' TY	
THESE DRAWINGS AND SPECIFICATIONS ARE THE PROPERTY OF FOXCONN INTERCONNECT TECHNOLOGY LIMITED, AND SHALL NOT BE REPRODUCED, COPIED OR USED IN ANY MANNER WITHOUT THE PRIOR WRITTEN CONSENT OF FOXCONN INTERCONNECT TECHNOLOGY LIMITED.				

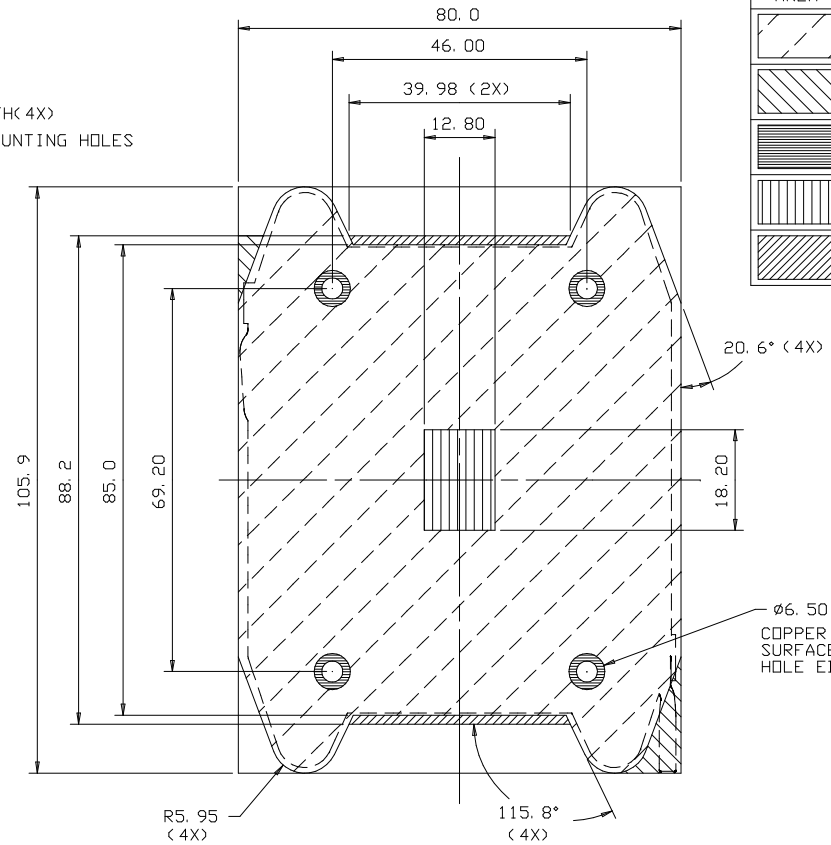
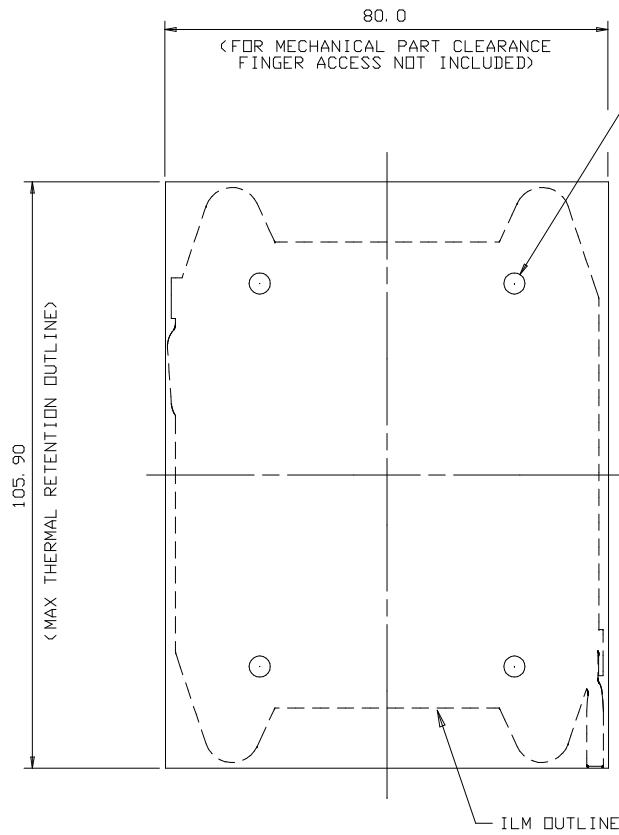

AREA	MAX. COMP. HT (mm)
	0.0 MM MAX COMPONENT HEIGHT <SOCKET AND ILM>
	1.4 MM MAX COMPONENT HEIGHT
	0.0 MM MAX COMPONENT HEIGHT <NO ROUTE ZONE>
	1.5 MM MAX COMPONENT HEIGHT <SOCKET CAVITY>
	1.6 MM MAX COMPONENT HEIGHT

ILM KEEPOUT ZONE OUTLINE

ILM VERTICAL KEEPOUT ZONE

X. ± 1.0	X. ° ± 1°	UNITS mm	NAME<INTENDED USE> LGA2011-3 NARROW ILM&BP	<b>FOXCONN®</b> FOXCONN INTERCONNECT TECHNOLOGY LIMITED.
. X ± 0.50	. X ° ±	MAT'L	PART NO.<INTENDED USE> PT44A12-4711	
. XX ± 0.30	. XX ° ±	FINISH	APPD: Nick Lin	CLASS: <input type="checkbox"/> CONFIDENTIAL <input type="checkbox"/> SECRET <input checked="" type="checkbox"/> GENERAL
. XXX ±	. XXX ° ±		Q' TY	CHKD: Dickie Huang Mac Peng
THESE DRAWINGS AND SPECIFICATIONS ARE THE PROPERTY OF FOXCONN INTERCONNECT TECHNOLOGY LIMITED, AND SHALL NOT BE REPRODUCED, COPIED OR USED IN ANY MANNER WITHOUT THE PRIOR WRITTEN CONSENT OF FOXCONN INTERCONNECT TECHNOLOGY LIMITED.			DR: Garnett Wu 4/27/ 14	DWG NO. : 351-0000-1241
			SCALE 1:1 SHEET 3/4 REV. C	

IDEAS GENERATED DRAWING, DO NOT CHANGE BY HAND.

NOTES:

1. ALL DIMENSIONS ARE IN MILLIMETERS.
2. DIMENSIONING AND TOLERANCING PER ASME Y14.5M-1994.
3. MATERIAL : BACK PLATE CARBON STEEL;  
STUD SCREWS CARBON STEEL;  
INSULATOR POLYCARBONATE;
4. "FOXCONN" "LGA2011 BP" "DATECODE" ARE LOCATED APPROXIMATELY.
5. PLEASE CONTACT INTEL FOR OFFICIAL KQZ RECOMMENDATION.
6. HARMFUL MATERIAL CONTROL PLEASE FOLLOW DOC. N.O. "EPI12".
7. PLEASE CONTACT FOXCONN SALES REPRESENTATIVE TO VERIFY PRODUCT DETAILS & AVAILABILITY.
8. THE CONCENTRATIONS OF Br & C<sub>i</sub> CAN SATISFY REQUIREMENTS OF HALOGEN-FREE IN DOC "EPI12".

REV.	ECN. NO.	APPD.

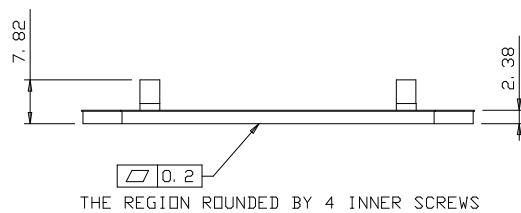
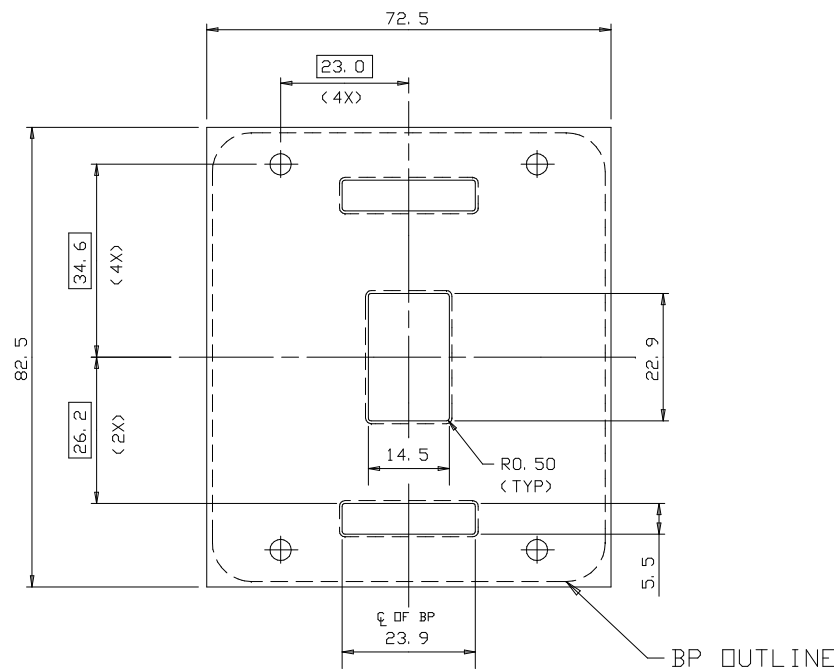
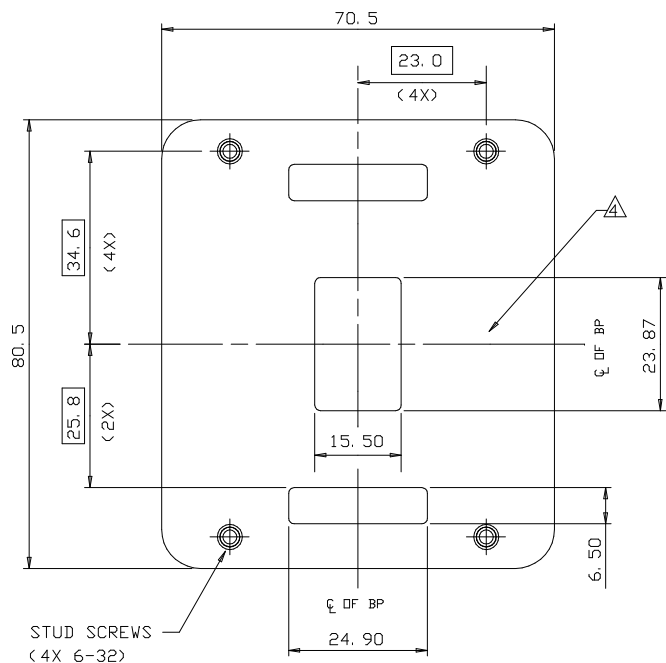
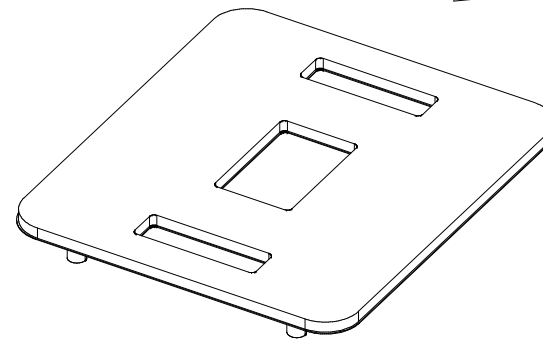

**RECOMMENDED PCB KEEPOUT ZONE**

X. ± 1.0	X. ° ± 1°	UNITS mm	NAME<INTENDED USE> LGA2011-3 NARROW ILM&BP	<b>Foxconn®</b> FOXCONN INTERCONNECT TECHNOLOGY LIMITED.
. X ± 0.50	. X ° ±	MAT'L	PART NO.<INTENDED USE> PT44A12-4711	
. XX ± 0.30	. XX ° ±	FINISH	APPD: Nick Lin	CLASS: <input type="checkbox"/> CONFIDENTIAL <input type="checkbox"/> SECRET <input checked="" type="checkbox"/> GENERAL
. XXX ±	. XXX ° ±		Q'TY	CHKD: Dickie Huang Mac Peng
THESE DRAWINGS AND SPECIFICATIONS ARE THE PROPERTY OF FOXCONN INTERCONNECT TECHNOLOGY LIMITED, AND SHALL NOT BE REPRODUCED, COPIED OR USED IN ANY MANNER WITHOUT THE PRIOR WRITTEN CONSENT OF FOXCONN INTERCONNECT TECHNOLOGY LIMITED.			DR: Garnett Wu 4/27' 14	DWG NO. : 351-0000-1241
			SCALE 1:1   SHEET 4/4   REV. C	