

NOTES: UNLESS OTHERWISE SPECIFIED

1. DIMENSIONS SHALL BE INTERPRETED PER ASME Y14.5M-1994.
2. SPECIFICATIONS ARE SHOWN ON DRAWING "307-0300-1104".
3. MATERIALS ARE SHOWN ON DDRAWING "307-0500-1104".  
 ⚠️ PRODUCT NO. MATRIX.: SEE 307-0500-1104.
5. PLEASE CONTACT FOXCONN SALES REPRESENTATIVE TO VERIFY PRODUCT DETAILS & AVAILABILITY.
6. HARMFUL MATERIAL CONTROL PLEASE FOLLOW FOXCONN'S DOC. "EP112".

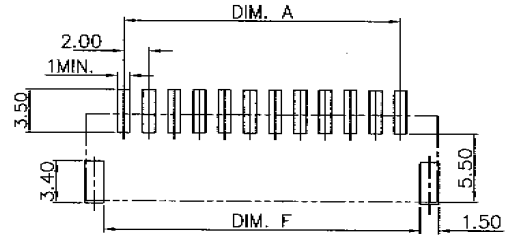

RECOMMEND P.C.B LAYOUT  
(TOLRANCE: ±0.05)

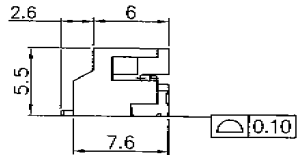
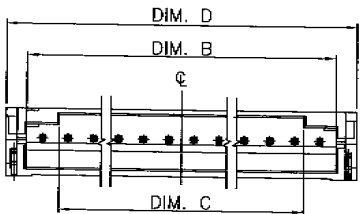
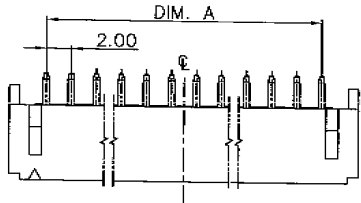
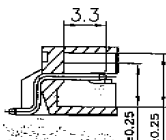
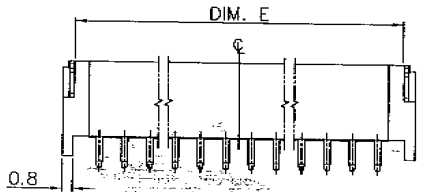

HS3214*	26.00	28.80	23.80	31.90	30.00	29.20
HS3212*	22.00	24.80	19.80	27.90	26.00	25.20
HS3210*	18.00	20.80	15.80	23.90	22.00	21.20
P/N	DIM. A	DIM. B	DIM. C	DIM. D	DIM. E	DIM. F

X.±	X.±	UNITS	mm	NAME (INTENDED USE)	<b>FOXCONN</b> HON HAI PRECISION IND. CO., LTD. TAIPEI, TAIWAN, R.O.C.
.X± 0.38	.X±	MAT'L		SMT HEADER	
.XX± 0.25	.XX±	FINISH		PART NO. (INTENDED USE)	TITLE:
.XXX±	.XXX±			HS32 Series	CUSTOMER DRAWING
THESE DRAWINGS AND SPECIFICATIONS ARE THE PROPERTY OF HON HAI PRECISION IND. CO., LTD. AND SHALL NOT BE REPRODUCED, COPIED OR USED IN ANY MANNER WITHOUT THE PRIOR WRITTEN CONSENT OF HON HAI PRECISION IND. CO., LTD.				APPD:	DRWG NO.:
				CHKD:	307-0000-1104
				DR:	SCALE   SHEET   REV.
					N/A   1/2   AX1

REV.	ECH. NO.	APPD.
------	----------	-------

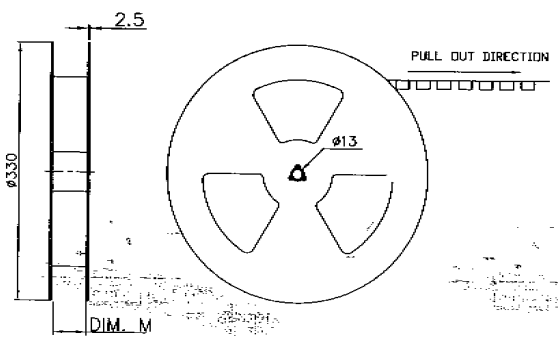
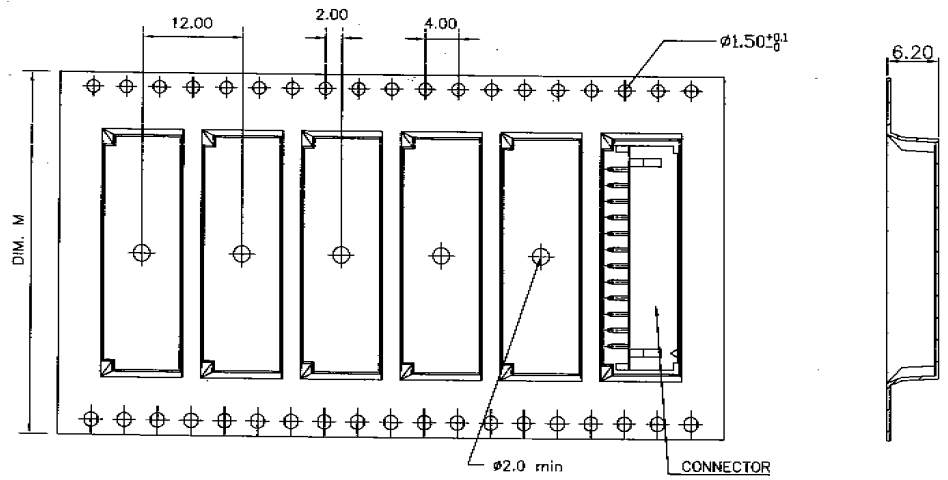

HS3214*	44.0	900 PCS/REEL
HS3212*	44.0	900 PCS/REEL
HS3210*	44.0	900 PCS/REEL
P/N	DIM. M	PACKAGING

X ±	X ±	UNITS	mm	NAME (INTENDED USE)	<b>FOXCONN</b> HON HAI PRECISION IND. CO., LTD. TAIPEI, TAIWAN, R.O.C.
.X ± 0.38	.X ±	MAT'L		SMT HEADER	
.XX ± 0.25	.XX ±			PART NO. (INTENDED USE)	TITLE: CUSTOMER DRAWING
.XXX ±	.XXX ±	FINISH		HS32 Series	DWG NO.: 307-0000-1104
THESE DRAWINGS AND SPECIFICATIONS ARE THE PROPERTY OF HON HAI PRECISION IND. CO., LTD. AND SHALL NOT BE REPRODUCED, COPIED OR USED IN ANY MANNER WITHOUT THE PRIOR WRITTEN CONSENT OF HON HAI PRECISION IND. CO., LTD.				APPD:	
		Q'TY		CHKD:	
				DR:	

SCALE	SHEET	REV.
N/A	1/2	AX1

DESC.	QTY	MATERIAL	TREATMENT	REMARK
CONTACT	SEE NOTES BELOW	COPPER ALLOY	A) 50u" MIN. NICKEL UNDER PLATING OVER ALL B) 100u" MIN. TIN PLATING WITH RoHS COMPLIANCE AT SOLDER TAIL AREA	
SOLDER PAD	1	COPPER ALLOY	A) 50u" MIN. NICKEL UNDER PLATING OVER ALL B) 100u" MIN. TIN PLATING WITH RoHS COMPLIANCE AT SOLDER PAD	
HOUSING		HIGH TEMPERATURE NYLON, THERMOPLASTIC, UL94V-0	HOUSING COLOR IVORY	

NOTES :

- HARMFUL MATERIAL CONTROL PLEASE FOLLOW FOXCONN'S DOC. "EPI12".
- PLEASE CONTACT FOXCONN SALES REPRESENTATIVE TO VERIFY PRODUCT DETAILS & AVAILABILITY.
- PRODUCT NO. MATRIX:

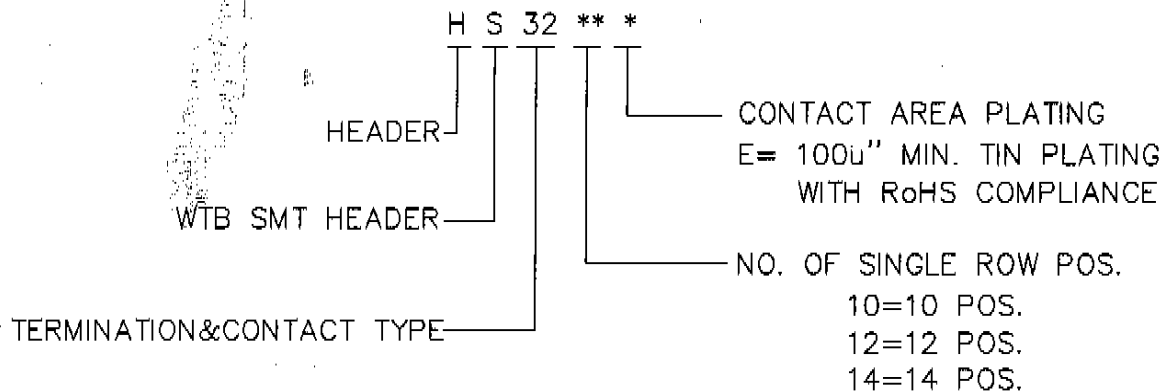

**FOXCONN** HON HAI PRECISION IND. CO.,LTD.  
TAIPEI, TAIWAN, R.O.C.

APPD. : <i>[Signature]</i>	TITLE : MATERIAL SHEET WIRE TO BOARD,SMT HEADER
CHKD. :	PROD. SERIES : HS32 SERIES
DR. : <i>[Signature]</i>	DWG. NO : 307-0500-1104
	REV. : AX1 SHEET : 1/1

A	HC052081	Yuson 8/8'05
REV.	ECN NO.	APPD.