

REV.	ECN. NO.	APPD.
A	HC95670	Jeff '950427
B	HC951264	I.K.Liu 8/26'95
C	BC0352255	Yihsin Chen 2/14,03
D	HC051060	Ady Zhou 2/19'05

NOTES:

1. ALL DIMENSIONS ARE IN MILLIMETERS WITH INCH EQUIVALENTS SHOWN IN BRACKETS.
2. MATERIALS OF ① AND ② ARE SHOWN ON DRAWING 307-0000-755.
3. POSITION NO. FOR REFERENCE ONLY.

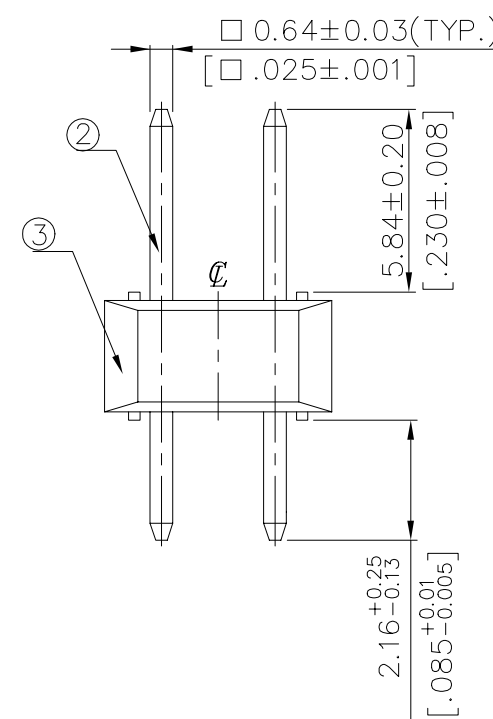
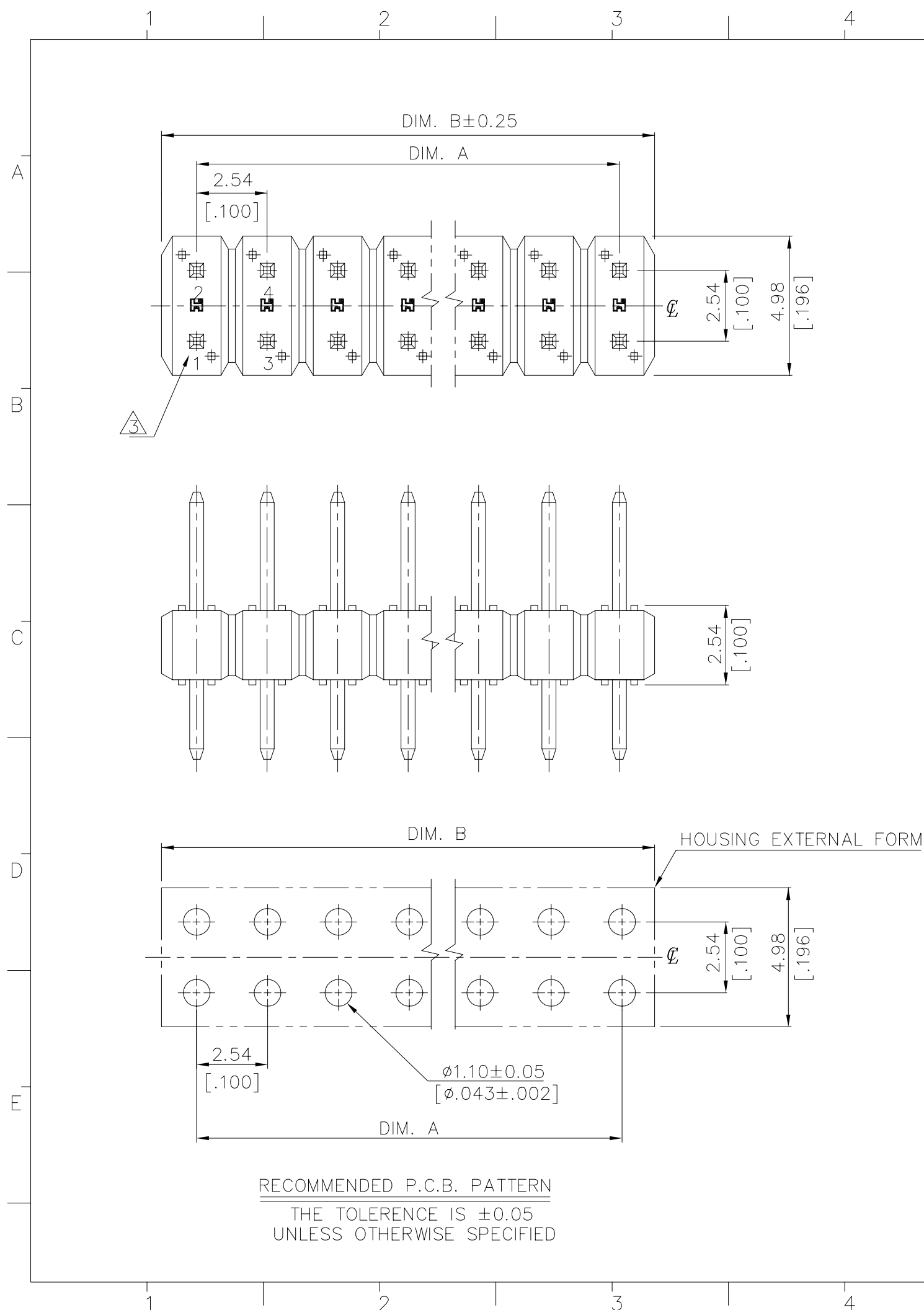

X. ±	X° ±	UNITS mm [INCH]	NAME (INTENDED USE)	FOXCONN HON HAI PRECISION IND. CO., LTD. TAIPEI, TAIWAN, R.O.C.
.X ± 0.25 [.010]	.X° ±	MAT'L	HEADER CONN., .025" SQ .100" CENTER, D/R.	
.XX ± 0.13 [.005]	.XX° ±		PART NO. (INTENDED USE)	TITLE:
.XXX ±	.XXX° ±	FINISH	HC19 SERIES	CUSTOMER DRAWING
THESE DRAWINGS AND SPECIFICATIONS ARE THE PROPERTY OF HON HAI PRECISION IND. CO., LTD. AND SHALL NOT BE REPRODUCED, COPIED OR USED IN ANY MANNER WITHOUT THE PRIOR WRITTEN CONSENT OF HON HAI PRECISION IND. CO., LTD.			APPD: Ady Zhou 2/19'05	DWG NO.:
			CHKD: Lik Wang 2/1'05	307-0000-222
			DR: Michael Li 1/25'05	
				SCALE SHEET REV.
				N/A 1/2 D

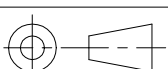
1	2		3		4					
NOTES: 1. [] [] [] [] : MODIFICATION CODE OPTION SEE DWG.: 307-0000-209			REV.	ECN.	NO.	APPD.				
A	PROD. NO.	CIRCUITS	DIM. A		DIM. B					
	HC1901*- [] [] [] []	1/2	0.00 [.000]		2.29[.090]					
	HC1902*- [] [] [] []	2/4	2.54 [.100]		4.83[.190]					
	HC1903*- [] [] [] []	3/6	5.08 [.200]		7.37[.290]					
	HC1904*- [] [] [] []	4/8	7.62 [.300]		9.91[.390]					
	HC1905*- [] [] [] []	5/10	10.16 [.400]		12.45[.490]					
	HC1906*- [] [] [] []	6/12	12.70 [.500]		14.99[.590]					
	HC1907*- [] [] [] []	7/14	15.24 [.600]		17.53[.690]					
	HC1908*- [] [] [] []	8/16	17.78 [.700]		20.07[.790]					
	HC1909*- [] [] [] []	9/18	20.32 [.800]		22.61[.890]					
	HC1910*- [] [] [] []	10/20	22.86 [.900]		25.15[.990]					
	HC1911*- [] [] [] []	11/22	25.40 [1.000]		27.69[1.090]					
	HC1912*- [] [] [] []	12/24	27.94 [1.100]		30.23[1.190]					
	HC1913*- [] [] [] []	13/26	30.48 [1.200]		32.77[1.290]					
	HC1914*- [] [] [] []	14/28	33.02 [1.300]		35.31[1.390]					
	HC1915*- [] [] [] []	15/30	35.46 [1.400]		37.85[1.490]					
	HC1916*- [] [] [] []	16/32	38.10 [1.500]		40.39[1.590]					
	HC1917*- [] [] [] []	17/34	40.64 [1.600]		42.93[1.690]					
	HC1918*- [] [] [] []	18/36	43.18 [1.700]		45.47[1.790]					
	HC1919*- [] [] [] []	19/38	45.72 [1.800]		48.01[1.890]					
	HC1920*- [] [] [] []	20/40	48.26 [1.900]		50.55[1.990]					
	HC1921*- [] [] [] []	21/22	50.80 [2.000]		53.09[2.090]					
	HC1922*- [] [] [] []	22/44	53.34 [2.100]		55.63[2.190]					
	HC1923*- [] [] [] []	23/46	55.88 [2.200]		58.17[2.290]					
	HC1924*- [] [] [] []	24/48	58.42 [2.300]		60.71[2.390]					
	HC1925*- [] [] [] []	25/50	60.96 [2.400]		63.25[2.490]					
	HC1926*- [] [] [] []	26/52	63.50 [2.500]		65.79[2.590]					
	HC1927*- [] [] [] []	27/54	66.04 [2.600]		68.33[2.690]					
	HC1928*- [] [] [] []	28/56	68.58 [2.700]		70.87[2.790]					
	HC1929*- [] [] [] []	29/58	71.12 [2.800]		73.41[2.890]					
	HC1930*- [] [] [] []	30/60	73.66 [2.900]		75.95[2.990]					
	HC1931*- [] [] [] []	31/62	76.20 [3.000]		78.49[3.090]					
	HC1932*- [] [] [] []	32/64	78.74 [3.100]		81.03[3.190]					
	HC1933*- [] [] [] []	33/66	81.28 [3.200]		83.57[3.290]					
	HC1934*- [] [] [] []	34/68	83.82 [3.300]		86.11[3.390]					
	HC1935*- [] [] [] []	35/70	86.36 [3.400]		88.65[3.490]					
	HC1936*- [] [] [] []	36/72	88.90 [3.500]		91.19[3.590]					
	HC1937*- [] [] [] []	37/74	91.44 [3.600]		93.73[3.690]					
	HC1938*- [] [] [] []	38/76	93.98 [3.700]		96.27[3.790]					
	HC1939*- [] [] [] []	39/78	96.52 [3.800]		98.81[3.890]					
	HC1940*- [] [] [] []	40/80	99.06 [3.900]		101.35[3.990]					
	X.±	X°±	UNITS	NAME(INTENDED USE)	FOXCONN					
	.X±	.X°±	MAT'L	HEADER CONN., .025" SQ., .100" CENTER, D/R.	HON HAI PRECISION IND. CO.,LTD. TAIPEI, TAIWAN, R.O.C.					
	.XX±	.XX°±		PART NO.(INTENDED USE) HC19 SERIES	TITLE: CUSTOMER DRAWING					
	.XXX±	.XXX°±	FINISH	APPD: Ady Zhou 2/19'05	DWG NO.: 307-0000-222					
	THESE DRAWINGS AND SPECIFICATIONS ARE THE PROPERTY OF HON HAI PRECISION IND. CO., LTD. AND SHALL NOT BE REPRODUCED, COPIED OR USED IN ANY MANNER WITHOUT THE PRIOR WRITTEN CONSENT OF HON HAI PRECISION IND. CO., LTD.			Q'TY	CHKD: Lik Wang 2/1'05			SCALE	SHEET	REV.
				DR: Michael Li 1/25'05	N/A			2/2	D	
	1	2	3	4						