

REV.	ECN. NO.	APPD.
X1	SMNKB1470B150	HUNG-CHI YU

IDEAS GENERATED DRAWING, DON'T CHANGE BY HAND.

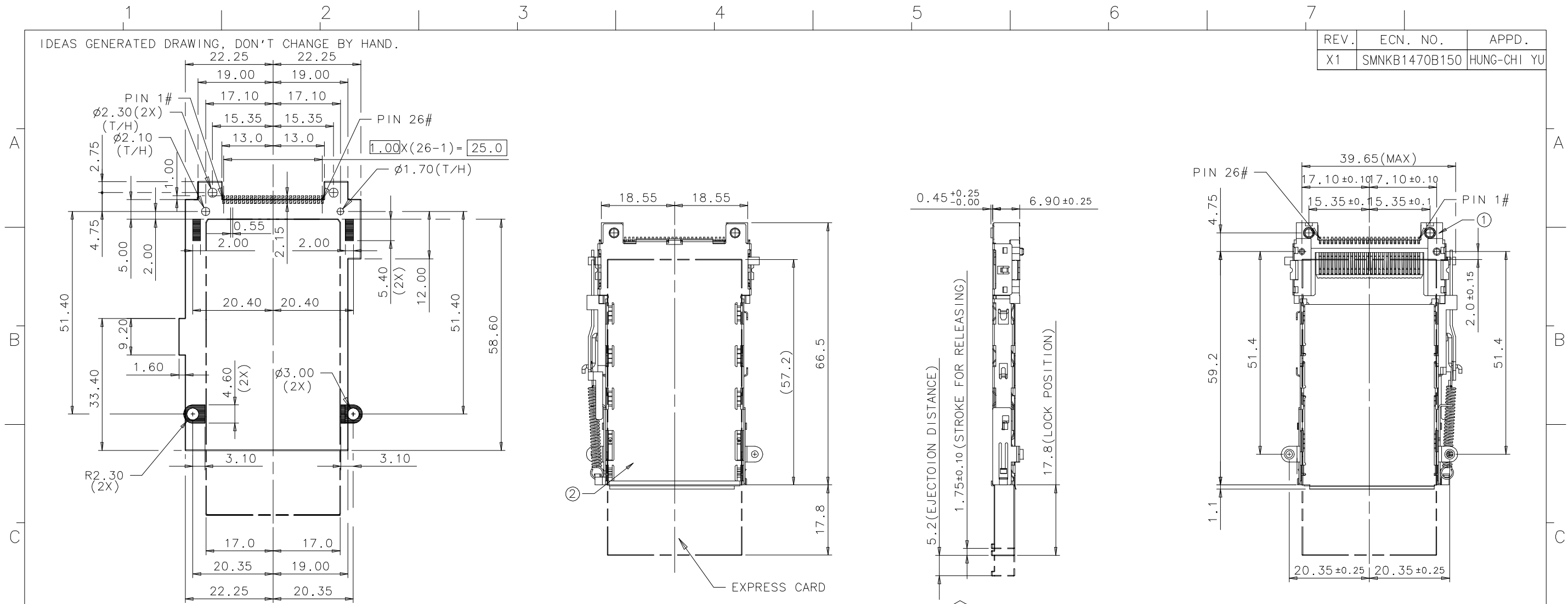

RECOMMENDED PCB LAYOUT

- KEEP OUT AREA
- SOLDER PAD
- GROUNDING PAD
- EXPRESS CARD AREA
- NO TRACE AREA

THE DEFAULT TOLERANCE IS ±0.05mm.

ITEM	COMPONENT P/N	QTY	DESCRIPTION
①	1CH411SC-MS	1	HEADER ASSEMBLY
②	1CX421S1-MS	1	GUIDERAIL FRAME WITH EJECTOR

NOTES:

- THE CONNECTOR WILL ACCEPT A EXPRESSCARD OF TYPE 1 WHICH IS RELEASED BY " EXPRESS CARD STANDARD "
- THE SCREWS ARE APPLIED FOR 1.5 Kg-cm MAXIMUM TORQUE TO FIT.
- THE LENGTH OF SCREWS IS SUGGESTED FROM 2.0mm TO 2.5mm.
- PLEASE CONTACT FOXCONN SALES REPRESENTATIVE TO VERIFY PRODUCT DETAILS & AVAILABILITY.

X. ± 0.30	X. ° ±	UNITS mm	NAME (INTENDED USE) EXPRESS CARD HOST CONNECTOR (TYPE 1/NORMAL)	FOXCONN HON HAI PRECISION IND. CO., LTD. TAIPEI, TAIWAN, R.O.C.
.X ± 0.25	.X ° ±	MAT'L	PART NO. (INTENDED USE) 1CH411SC-MS 1CX421S1-MS	
.XX ± 0.20	.XX ° ±	FINISH	APPD: HUNG-CHI YU	TITLE: CUSTOMER DRAWING
.XXX ±	.XXX ° ±		Q'TY	CHKD: Cheery Chen
THESE DRAWINGS AND SPECIFICATIONS ARE THE PROPERTY OF HON HAI PRECISION IND. CO., LTD. AND SHALL NOT BE REPRODUCED, COPIED OR USED IN ANY MANNER WITHOUT THE PRIOR WRITTEN CONSENT OF HON HAI PRECISION IND. CO., LTD.			DR: SONIC ZHU 11/23'07	SCALE SHEET REV. N/A 1/4 X1

PROPOSAL

IDEAS GENERATED DRAWING, DON'T CHANGE BY HAND.

REV.	ECN. NO.	APPD.

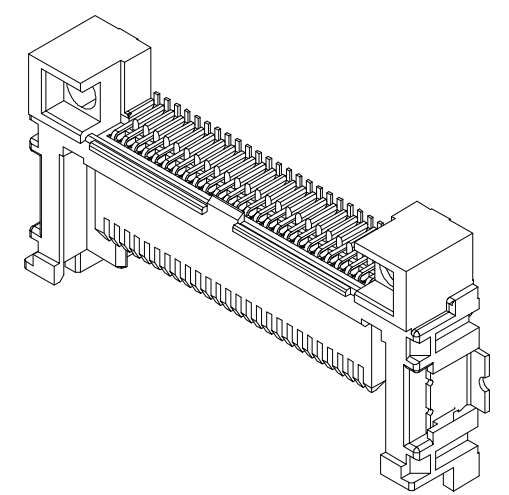
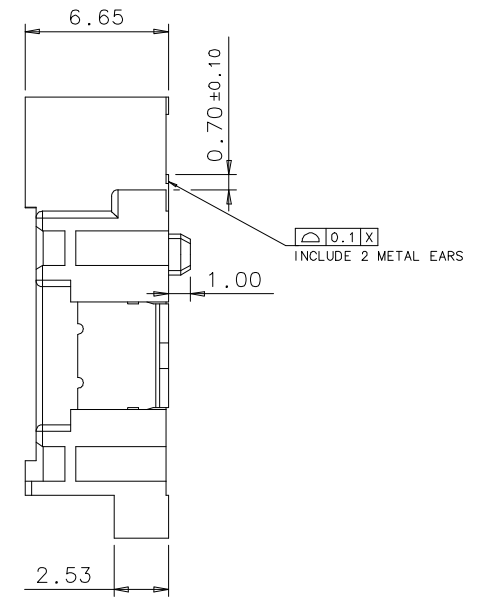
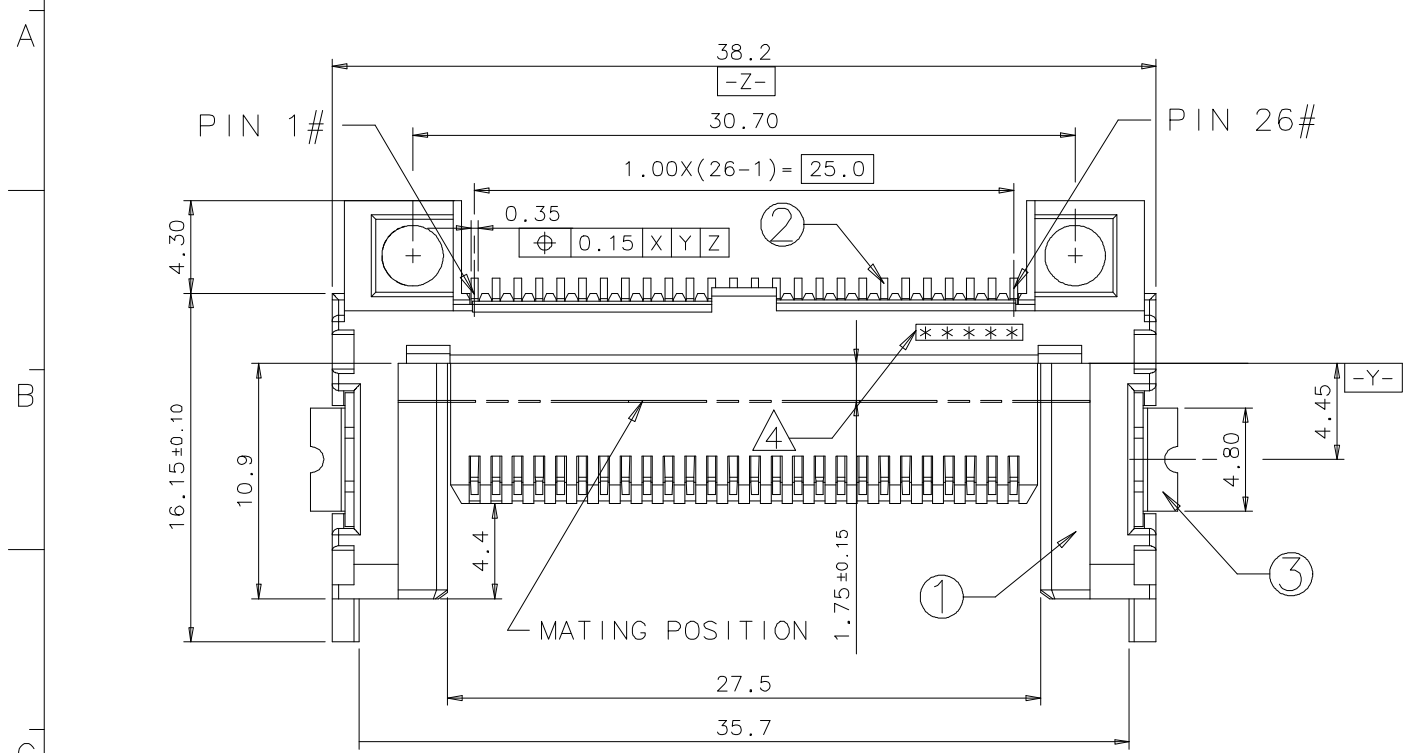

- NOTES:
- ELECTRICAL SPECIFICATION:
 - 1-1 CONTACT CURRENT RATING : $\Delta T < 30^{\circ}\text{C}$ AT 0.75 AMPERE PER PIN.
 - 1-2 DIELECTRIC WITHSTANDING VOLTAGE : 500V AC MAXIMUM.
 - 1-3 INSULATION RESISTANCE : 100 Megohms MINIMUM AFTER TEST.
 - MECHANICAL SPECIFICATION:
 - 2-1 CONNECTOR MATING FORCE : 39 N MAXIMUM AT 12.5 mm/Min.
 - 2-2 CONNECTOR UNMATING FORCE : 3.7 N MINIMUM 18.5 N MAXIMUM AT 12.5 mm/Min.
 - 2-3 DURABILITY: 10,000 CYCLES.
 - ENVIRONMENT SPECIFICATION:
 - 3-1 OPERATING TEMPERATURE: -55°C TO $+85^{\circ}\text{C}$, 95% RH MAXIMUM.
 - DATE CODE IS PRINTED BY THE BLACK INK ON THE SIDE. HEIGHT=2.0mm.
 - THIS PART IS LEAD FREE PRODUCT.
 - PLEASE CONTACT FOXCONN SALES REPRESENTATIVE TO VERIFY PRODUCT DETAILS & AVAILABILITY.

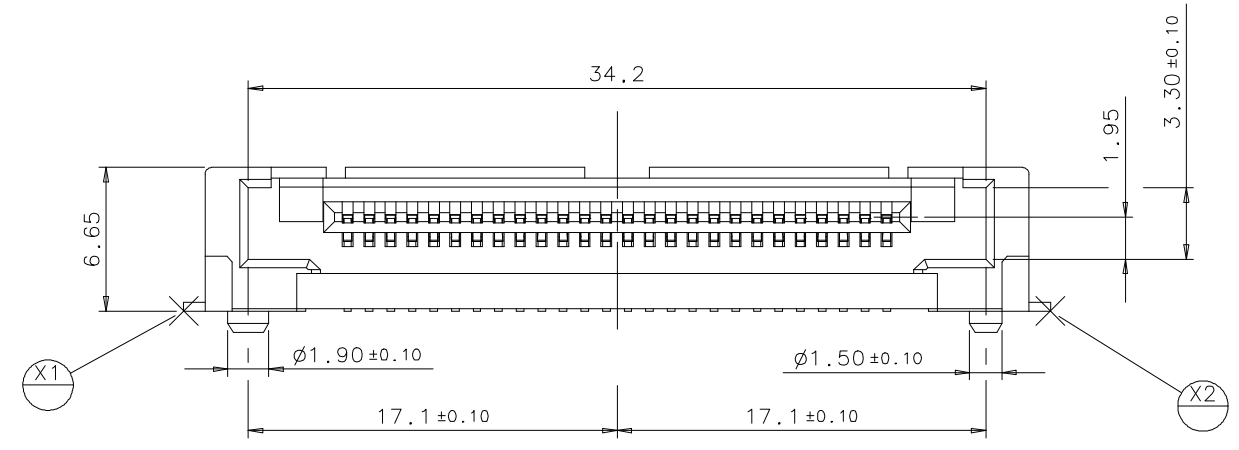

PART LIST
 1CH411SC-MS
 C: GOLD PLATING
 S: STANDOFF HEIGHT=1.2mm
 1: NORMAL TYPE
 H: HEADER

PROPOSAL

③	METAL EAR	2	COPPER ALLOY	CLEAN	
②	CONTACT PIN	26	COPPER ALLOY	GOLD PLATING AT CONTACT AREA. TIN PLATING AT TERMINATION NICKEL UNDERPLATING OVERALL.	
①	HOUSING	1	HI-TEMP THERMOPLASTIC UL 94V-0	MOLDED COLOR: WHITE	
ITEM	DESCRIPTION	QT'Y	METERIAL	FINISH	REMARK
X. ± 0.30	X. ° ±	UNITS	mm	NAME (INTENDED USE) EXPRESS CARD HOST CONNECTOR (TYPE 1/NORMAL)	
.X ± 0.25	.X ° ±	MAT'L		PART NO. (INTENDED USE) 1CH411SC-MS	
.XX ± 0.20	.XX ° ±	FINISH		TITLE: CUSTOMER DRAWING	
.XXX ±	.XXX ° ±	Q'TY		APPD: HUNG-CHI YU CHKD: Cheery Chen DR: SONIC ZHU 11/23'07	
THESE DRAWINGS AND SPECIFICATIONS ARE THE PROPERTY OF HON HAI PRECISION IND. CO., LTD. AND SHALL NOT BE REPRODUCED, COPIED OR USED IN ANY MANNER WITHOUT THE PRIOR WRITTEN CONSENT OF HON HAI PRECISION IND. CO., LTD.				FOXCONN HON HAI PRECISION IND. CO., LTD. TAIPEI, TAIWAN, R.O.C. DWG NO.: 331-1CX421S1-MS SCALE SHEET REV. N/A 2/4 X1	

IDEAS GENERATED DRAWING, DON'T CHANGE BY HAND.

REV.	ECN. NO.	APPD.

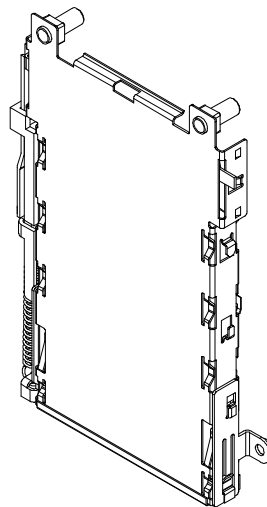
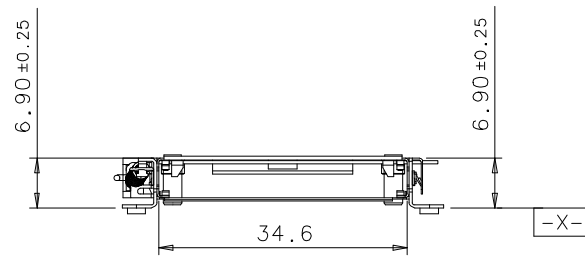
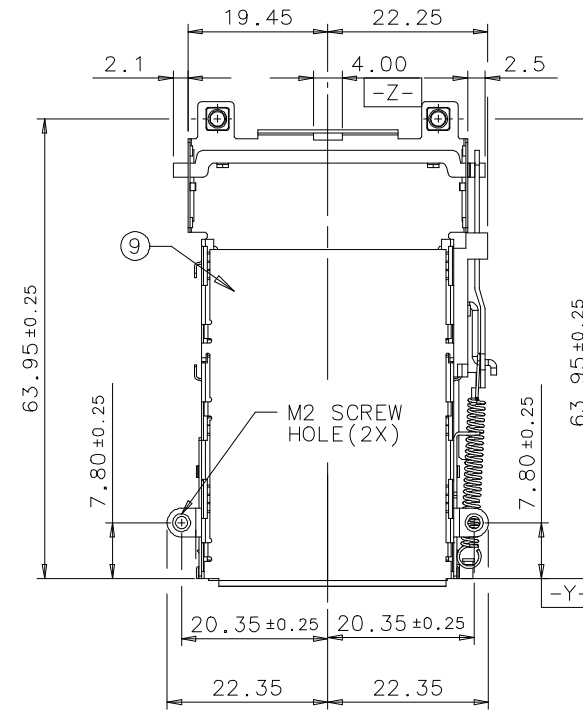
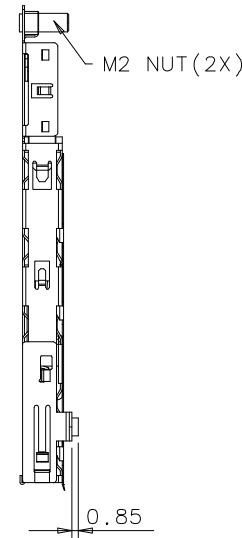
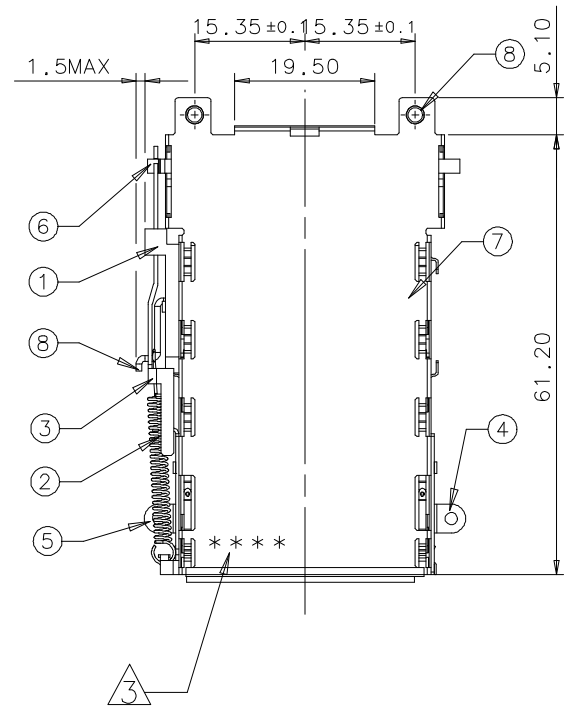

PROPOSAL

PART LIST

1CX421S1-MS

- S: STAND OFF HEIGHT=1.2mm
- 2: TYPE 1 ONLY
- X: EJECTOR

NOTES:

1. THE SCREWS ARE APPLIED FOR 1.5 Kg-cm MAXIMUM TORQUE TO FIT.
2. THE LENGTH OF SCREW IS SUGGESTED FROM 2.0 mm TO 2.5 mm.
3. DATE CODE IS PRINTED BY THE BLACK INK ON THE SIDE, HEIGHT=2.0mm.
4. PLEASE CONTACT FOXCONN SALES REPRESENTATIVE TO VERIFY PRODUCT DETAILS & AVAILABILITY.

ITEM	DESCRIPTION	QTY	MATERIAL	FINISH	REMARK
⑨	BOTTOM PLATE	1	STEEL	CLEAN	
⑧	NUT	2	COPPER ALLOY	CLEAN	
⑧	SLIDE PIN	1	STEEL	CLEAN	
⑦	SHELL	1	STEEL	CLEAN	
⑥	LEVEL	1	STEEL	CLEAN	
⑤	STAND OFF(RIGHT)	1	STEEL	CLEAN	
④	STAND OFF(LEFT)	1	STEEL	CLEAN	
③	METAL BAR	1	STEEL	CLEAN	
②	SPRING	1	SWP-B	CLEAN	
①	CAMPLATE	1	HI TEMP. THERMOPLASTIC UL 94V-0	MOLDED COLOR: BROWN	

X. ± 0.30	X. ° ±	UNITS mm	NAME (INTENDED USE) EXPRESS CARD HOST CONNECTOR (TYPE 1/NORMAL)	FOXCONN HON HAI PRECISION IND. CO., LTD. TAIPEI, TAIWAN, R.O.C.
.X ± 0.25	.X ° ±			
.XX ± 0.20	.XX ° ±	FINISH	PART NO. (INTENDED USE) 1CX421S1-MS	TITLE: CUSTOMER DRAWING
.XXX ±	.XXX ° ±			
THESE DRAWINGS AND SPECIFICATIONS ARE THE PROPERTY OF HON HAI PRECISION IND. CO., LTD. AND SHALL NOT BE REPRODUCED, COPIED OR USED IN ANY MANNER WITHOUT THE PRIOR WRITTEN CONSENT OF HON HAI PRECISION IND. CO., LTD.			APPD: HUNG-CHI YU	DWG NO.: 331-1CX421S1-MS
			CHKD: Cheery Chen	
DR: SONIC ZHU 11/23'07				

IDEAS CREATED DRAWING, DON'T CHANGE BY HAND.

REV.	ECN. NO.	APPD.

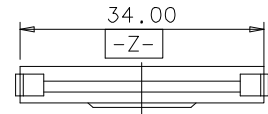
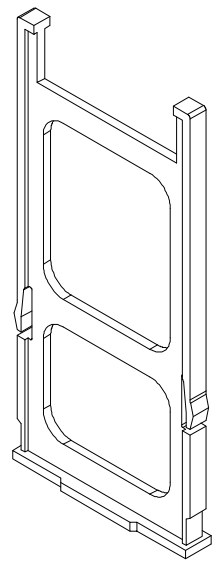

NOTES:
 1. MATERIAL: PBT, COLOR: BLACK.
 2. THE ID CAN BE CHANGED TO FOLLOW THE CUSTOMER'S REQUEST.
 3. PLEASE CONTACT FOXCONN SALES REPRESENTATIVE TO VERIFY PRODUCT DETAILS & AVAILABILITY.

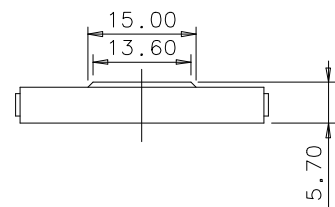
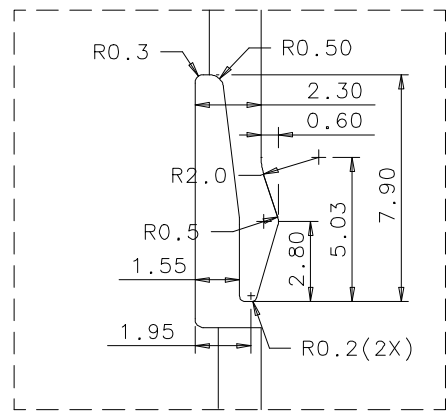
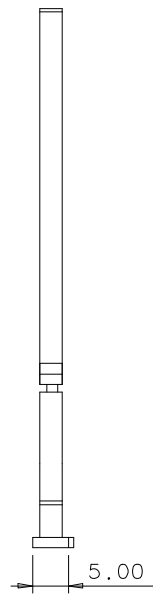
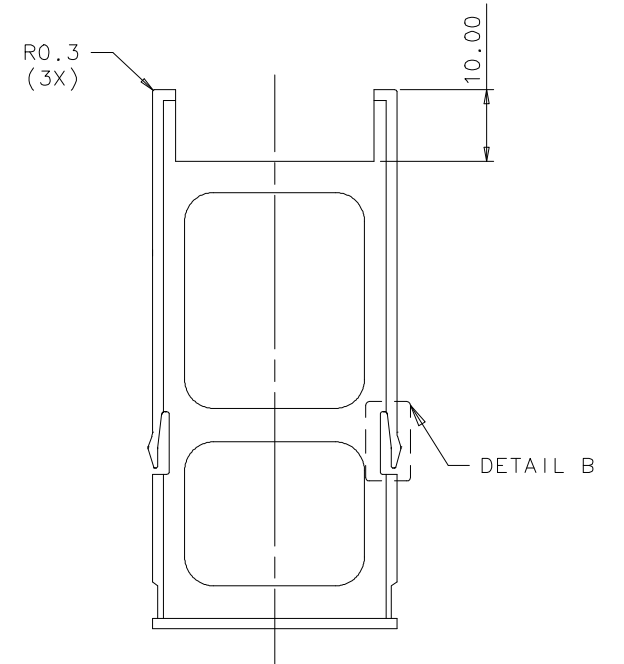
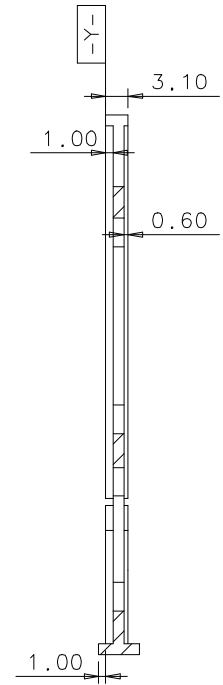
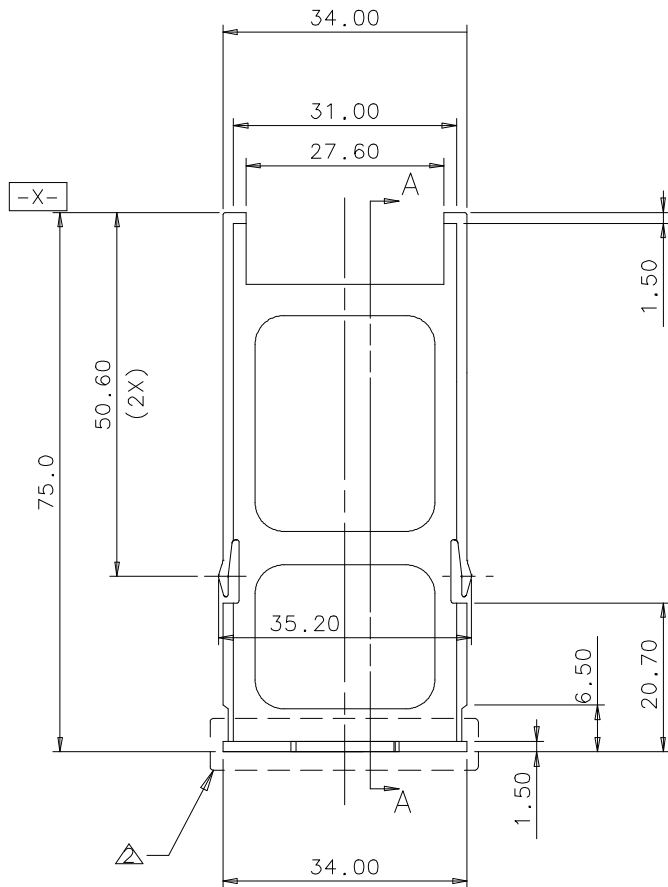

PROPOSAL

X. ± 0.20	X. ° ±	UNITS mm	NAME (INTENDED USE) EXPRESS CARD DUMMY CARD	FOXCONN HON HAI PRECISION IND. CO., LTD. TAIPEI, TAIWAN, R.O.C.
.XX ± 0.10	.X ° ±	MAT'L		
.XX ± 0.05	.XX ° ±	△	PART NO. (INTENDED USE) 1CX421S1-MS	TITLE: CUSTOMER DRAWING
.XXX ±	.XXX ° ±		FINISH	APPD: HUNG-CHI YU
THESE DRAWINGS AND SPECIFICATIONS ARE THE PROPERTY OF HON HAI PRECISION IND. CO., LTD. AND SHALL NOT BE REPRODUCED, COPIED OR USED IN ANY MANNER WITHOUT THE PRIOR WRITTEN CONSENT OF HON HAI PRECISION IND. CO., LTD.			Q'TY	CHKD: Cheery Chen
			DR: SONIC ZHU 11/23'07	SCALE SHEET REV. N/A 4/4 X1